

# COMEC

MACCHINE PER CONTRAFFORTI E SOTTOPIEDI  
MACHINES FOR COUNTERS AND INSOLES



garbatrice  
moulding machine

A/29

linea contrafforti  
counters line

TERMOPLASTICO / THERMOPLASTIC MATERIAL

linea contrafforti  
counters line



garbatrice | moulding machine

A/29

La GARBATRICE mod. A/29 è una macchina per garbare in automatico i contrafforti in materiale termoplastico. La macchina è controllata da un pannello touch-screen.

Il riscaldamento del contrafforte termoplastico viene effettuato tramite lampade infrarossi e lo stampo viene raffreddato da un gruppo frigo.

La garbatura del contrafforte viene effettuata tramite un movimento biella-manovella comandato da un motore elettromeccanico.

Dopo la garbatura i contrafforti vengono estratti automaticamente dallo stampo e depositati su un nastro riordinatore. La macchina è costruita a normative CE.

The MOULDING MACHINE mod. A/29 is a machine for the automatic moulding of the thermoplastic counters. The machine is checked by a touch-screen panel.

The heating of the thermoplastic counter is made by infrared rays lamps and the mould is cooled by a refrigerated group.

The counter moulding is made by a connecting rod-crank movement controlled by an electromechanical motor.

After the moulding the counters are automatically drawn from the mould and placed on a reorganiser belt.

The machine is made according CE instructions.

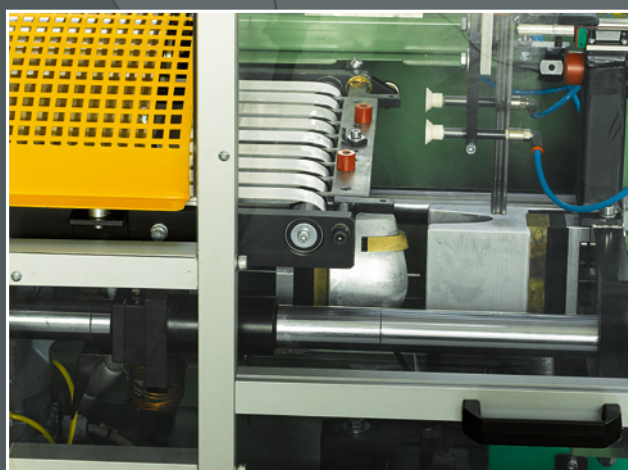

COMEC

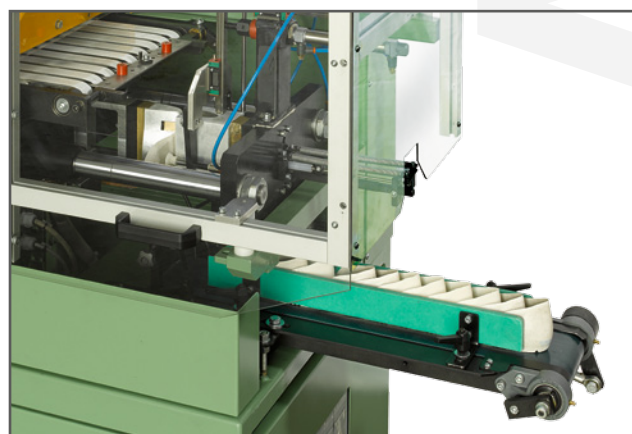
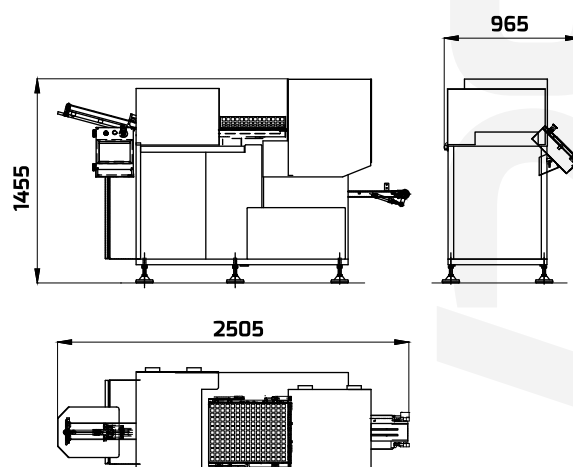

**Funzionamento Elettronico Meccanico**

Operation Electronic-mechanical

**Produzione oraria max** 500 paia  
Max hourly output pairs

**Alimentazione** 230/400 V  
Supplied Voltage

**Potenza assorbita max** 3 Kw  
Absorbed Power

**Consumo aria** 300 NI/min  
Air consumption

**Peso complessivo** 450 Kg  
Overall weight of the machine

COMEC SRL SI RISERVA IL DIRITTO DI MODIFICARE IN QUALUNQUE MOMENTO IL SUO PRODOTTO SENZA PREAVVISO  
COMEC RESERVES THE RIGHT TO MAKE CHANGEMENTS ON THE PRODUCT AT ANY TIME, WITHOUT NOTICE

COMEC s.r.l.  
via Copernico 58/60  
36034 Malo (Vicenza) - Italy  
tel +39 0445 588021  
fax +39 0445 588011  
info@comec-italy.com  
www.comec-italy.com